

Revolutionizing Gum Tapping : A Manual Blazer for *Moringa oleifera* Gum Tapping

SC SHARMA^{1*}, SK PANDEY², N PRASAD³ AND H RAJ⁴

ABSTRACT

Natural gums are among the important non timber forest products and are produced from a wide range of plants. Devices for commercially important gums tapping from selected tree species have been developed and standardized but manually operated light weight efficient device for *moringa gum* tapping from *Moringa oleifera* trees is lacking. Considering the need, a manually operated portable blazer for sustainable gum tapping from *Moringa oleifera* trees was developed and evaluated in actual field condition. Developed gum tapping blazer consists of working blade, depth control mechanism and handle. During the process of *moringa gum* tapping experiment from *Moringa oleifera* trees utilizing developed blazer, it was observed that blazes on the tree trunk of *Moringa oleifera* trees could be easily made using developed blazer having sharp edges in semicircular shape. Developed gum tapping blazer was operated easily without any problem. Depth control mechanism provided in the developed gum tapping blazer was also found working as per requirement and suitable for operating the blazer easily. Developed blazer is portable, manually operated and user friendly equipment. Mean yield of *moringa gum* was found 59.76 g with minimum mean gum production 2.19 g in the month of October, 2020 and mean maximum gum production 257.85 g in the month of July, 2021, respectively. Semi circular blazes on the tree trunk of *Moringa oleifera* trees for *moringa gum* tapping can be develop easily with reduced manpower requirement, drudgery and time utilizing developed gum tapping blazer.

Keywords: Devices, Gum extraction, Gum tapping blazer/die, Moringa gum, Tool

ARTICLE INFO

Received on	:	14.02.2024
Accepted on	:	25.03.2024
Published online	:	31.03.2024



INTRODUCTION

Natural gums are derived from the selected tree species and produced by plants in the form of sticky exudates and nodules spontaneously (Sharma *et al.*, 2016a). Plant gums and mucilage widely have been used in various industries like paper, textile, food, ink, cosmetics, petroleum and frequently used in pharmaceuticals as thickening, binding, emulsifying, suspending, stabilizing agents and coating materials in micro encapsulation (Gordon *et al.*, 1990; Shivalingam *et al.*, 2010). Gum sector is one of the most important sources of livelihood support for rural population inhabiting forest and sub forest area besides being a major source of employment (Sharma and Prasad, 2013). Gums are viscous secretion of some trees and shrubs that are solids consisting of mixtures of polysaccharides (carbohydrates) which are either water-soluble or absorb water and swell up to form a gel or jelly when placed in water (Sharma *et al.*, 2023). Gums are produced by plants of number of families but commercial exploitation is limited to a few tree species (Prasad *et al.*, 2012). The gum exudes from the trees by tapping of blazes made by stripping off the bark (Sharma *et al.*, 2018a). The quantity of gum exudes varies from tree to tree, depending upon its

genetic character and climatic conditions. There are various views about the function of gum in the plant. Some believe that the gum is part and parcel of normal metabolism of the plant. In some cases the production of gum has been attributed to fungi attacking the plant. Natural gum offers abundant opportunities for development of high value product and industrial applications and is a promising area for income generation and small scale entrepreneurship development for unemployed rural youths in aspirational districts of India. Natural gums make a significant contribution to the foreign exchange earnings and play an important role in the economy of the country. Use of gums for domestic consumption and sale to earn some cash is very common among the forest dwelling communities, particularly tribals in India. It is admitted fact that neither the forest nor the tribals and poor inhabiting in the area should be removed for environmental protection (Sharma *et al.*, 2018b; Giri *et al.*, 2008; Sharma *et al.*, 2013). Thousands of forest dwellers particularly in the central and western Indian states depend on gums as a viable source of income. Gums, commonly used in everyday life, are having ample

¹ Sr. Scientist, Automation & Plant Engineering Division

² Scientist (SG), Agri-business Development Unit

³ Pr. Scientist & Head, Agri-bioresources Augmentation Division

⁴ Ex-Senior Research Fellow, ICAR – National Institute of Secondary Agriculture, Ranchi (Jharkhand) INDIA.

*Corresponding Author E-mail: schsharma09@yahoo.co.in

importance as Non-Timber Forest Produce. Natural gums are non-toxic, biodegradable and eco-friendly for use in various industries (Sharma *et al.*, 2018c). Generally, natural gums are collected in small quantities by forest dwellers by adopting traditional tapping methods (Sharma *et al.*, 2016b). Benefit mainly depends on the quality of the produce (Sharma *et al.*, 2023). Therefore, there is tremendous potential of gum tapping from selected tree species to enhance gum production.

Moringa oleifera, native to India, grows in the tropical and subtropical regions of the world and is commonly known as 'drumstick tree' or 'horseradish tree' (Lakshmipriya *et al.*, 2016). The gum exudes from *Moringa oleifera* tree is initially white in colour but changes to reddish brown to brownish black on exposure (Shah *et al.*, 2011; Thombare *et al.*, 2018). *Moringa* is small, lovely, deciduous tree with thin foliage and crooked tree trunk, habitually forked from near the base including smooth corky grey bark, wide and open crown resembling umbrella shaped. Branches of *moringa* tree are easily breakable due to soft in nature. Leaves are alternate, tripinnate, bearing leaflets in opposite pairs having terminal leaflet slightly larger than others and rounded – elliptic. Flowers are small, whitish and honey scented with heavy flowering in clusters on panicles. Fruits of *moringa* trees are elongated capsule with approximately 9 seeds, when dried splits and dispersed in the wind with three – cornered wings (Thombare *et al.*, 2018).

Moringa gum is used as an abortifacient, to treat headaches, fevers, dysentery, asthma and intestinal cancer. The gum is diuretic, astringent and abortifacient and is used against asthma (Das, 2014). Tools and technique of gum tapping has been standardized for different gums (*i.e.* gum *karaya*, gum *arabic* and *guggul* etc.) by previous researchers but no documentation on *moringa* gum tapping tool and technique are available. Gum tapping from *Moringa oleifera* trees can provide additional income to rural and tribal people. Thus need was felt to develop *moringa* gum tapping blazer so that maximum gum may be produced from *Moringa oleifera* trees in this region with minimum injury to the trees.

MATERIALS AND METHODS

Location specific traditional gum tapping tools used by forest dwellers for gum production from selected tree species are brutal, less efficient, time consuming, injurious to the plants (leading to their death) and having problem in handling and its operation (Sharma *et al.*, 2016a). Thus, a light weight hand tool "Gum Tapping Blazer" was designed at ICAR – National Institute of Secondary Agriculture (Formerly: Indian Institute of Natural Resins and Gums), Ranchi in collaboration with ICAR – Central Institute of Agricultural Engineering, Bhopal utilizing the facility of Pro Engineer CAD Software and fabricated locally at Ranchi based on detailed manufacturing design drawing developed in above mentioned software to maintain the uniform shape, size and depth of blaze on the tree trunk for *moringa* gum tapping. Detailed description of the developed gum tapping blazer is as under.

Development of gum tapping blazer

A light weight manually operated gum tapping blazer for *moringa* gum tapping from *Moringa oleifera* trees was

developed at Automation & Plant Engineering Division, ICAR – National Institute of Secondary Agriculture, Ranchi based on detailed manufacturing design drawing developed in Pro Engineer (Cero Element) CAD software, consisted of three major components *i.e.* working blade, depth control mechanism and handle (Fig. 1 and 2). The overall dimension *i.e.* length, width and height of the developed gum tapping blazer was 304×126.5×79 mm, respectively. The detailed description of above components is as under:

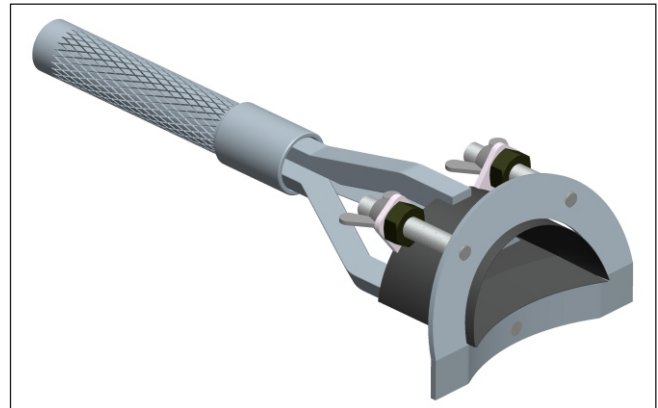

Fig. 1: Gum tapping blazer designed in Pro Engineer (Cero Element) CAD software

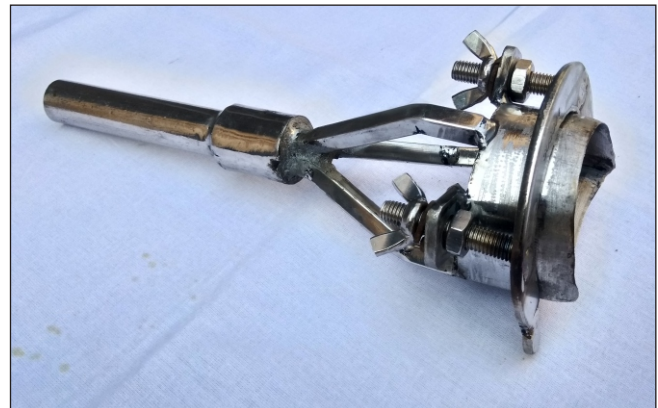

Fig. 2: Developed gum tapping blazer

Working blade

Working blade of gum tapping blazer was made with two pieces of stainless-steel plate. Base plate of the working blade was made of size 84 mm length, 60 mm width and 3 mm thickness stainless steel plate. Part of stainless-steel plate at front end of the blade was removed in curved shape with radius 86 mm upto 11 mm depth to fix the blade properly on the tree trunk and chamfered from curved end to 25.4 mm deep to make the sharp edge. Another piece of stainless-steel plate of size 120 mm length and same width and thickness was taken and bent in semicircular shape of length 86 mm and height 38.5 mm with radius 40.5 mm. Front end of the semicircular shaped blade made of stainless-steel plate was also removed in curved shape with radius 169 mm upto 11 mm depth and chamfered from curved end to 25.4 mm deep for making sharp edge. Semicircular shaped stainless-steel plate was then welded with the base plate of the working blade in such a way that sharp edge of both the pieces of

stainless steel plate should match properly with curved edge. A rectangular piece of stainless-steel plate of size 23 mm length, 20 mm width and 3 mm thickness was taken and a hole of diameter 10.5 mm was developed at 13 mm distance from one end length wise at the centre. The stainless-steel plate of size 23 mm length, 20 mm width and 3 mm thickness having 10.5 mm diameter hole was welded vertically outside the base plate surface at the centre opposite to sharp edge. Similarly, another two pieces of same dimension having hole of diameter 10.5 mm were welded vertically outside the semicircular shaped stainless steel plate surface opposite to the sharp edge at both sides having 37.7° angle from vertical position (Fig. 3). These three pieces of stainless-steel plates having hole of diameter 10.5 mm serves the purpose of fixing the depth control mechanism to maintain the uniform depth on the tree trunk for *moringa* gum tapping from *Moringa oleifera* trees.

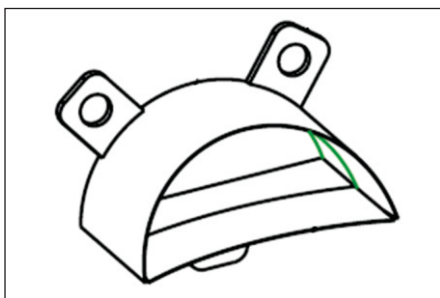

Fig. 3: Working blade

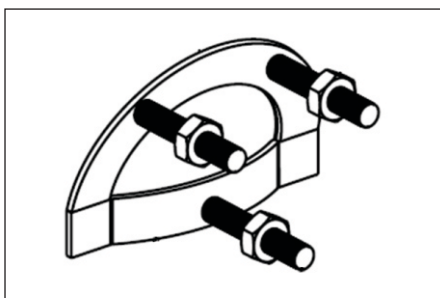

Fig. 4: Depth control mechanism

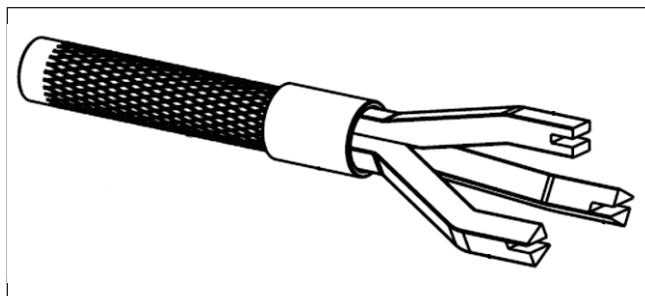

Fig. 5: Handle

Depth control mechanism

Depth control mechanism of gum tapping blazer was made with two pieces of stainless-steel plate. Base plate of the depth control mechanism was made of stainless-steel plate of size 131 mm length, 20 mm height and 3 mm thickness. Base plate of the depth control mechanism was curved with radius 85.5

mm upto 11 mm depth vertically at centre from 20 mm distance from both ends to fix the depth control mechanism properly on the tree trunk. A hole of size 7 mm diameter was also developed at the centre of base plate of depth control mechanism. Another piece of stainless-steel plate having semicircular shape with size 126.33 mm length, 20 mm height and 3 mm thickness having two holes of diameter 7 mm at a height of 40.7 mm from base of depth control mechanism both side at central position and at 68 mm distance apart (34 mm both side from central position) was welded vertically with base plate of the depth control mechanism. A bolt having diameter 10 mm and length 62 mm without head was taken and diameter at one end of the bolt was reduced to 7 mm from 10 mm upto 3 mm depth lengthwise and welded in the hole (7 mm) made on the base plate. Similarly, two bolts of same dimension were taken and modified as discussed above and welded by placing the modified end of bolts in the holes of size 7 mm diameter made on the semicircular shaped stainless-steel plate of depth control mechanism (Fig. 4). After fixing the bolts with base plate and semicircular shaped stainless-steel plate of depth control mechanism, the working blade unit of the gum tapping blazer was placed inside the depth control mechanism by matching the base plate of the working blade and base plate of the depth control mechanism. After placing the working blade inside the depth control mechanism, free end of bolts welded with depth control mechanism were inserted in the holes of stainless-steel plate (23 mm length, 20 mm width and 3 mm thickness having 10.5 mm diameter hole) welded outside the working blade opposite to sharp edge and fixed using nut to make the depth control mechanism as an integral part of the working blade of gum tapping blazer (Fig. 1).

Handle

Handle of gum tapping blazer was made of 135 mm long stainless-steel rod of diameter 25 mm. Diameter of the rod was reduced to 20 mm from 25 mm at one end upto 20 mm depth lengthwise and another end was chamfered at 45° angles from bigger diameter end up to 0.5 mm depth lengthwise to make the end corner smooth for ease in handling and operation. Diamond knurling was also developed on the outer surface of the stainless-steel rod after 22.7 mm distance from face of reduced diameter end and 12.7 mm after chamfered end towards free end to make the surface rough for slip free operation and handling of gum tapping blazer. Another piece of stainless-steel rod having diameter 30 mm and length 40 mm was taken and bored from one end at central position up to 20 mm depth to make hole of size 25 mm inner diameter. A bore of size 20 mm diameter also developed at central position from another end upto 20 mm depth. Both ends corners of the bored piece of stainless steel were chamfered at 45° angle up to 0.5 mm depth lengthwise to make the corner ends smooth for trouble free handling and operation. A square stainless-steel rod of length 120 mm, width 12 mm and height 12 mm was taken and bent from 30 mm distance from both the ends in opposite direction. At one end of the bent square rod, rectangular slit of size 12 mm length, 10 mm width and 3.5 mm height were developed and another end was kept as such. Similarly, two more pieces of stainless-steel square rod of same width and height having length 126 mm was taken. Both

the square rods were bent from both the ends in opposite direction at a distance 30 mm. At one end of both the square rod, slit of 12 mm length, 10 mm width and 3.5 mm thickness were developed and another end was kept as such. All the three-square rod from slit end was placed on the body of working blade and welded (Fig. 5) and other end of all the three rods were inserted in to the small piece of stainless-steel rod having 20 mm diameter bore and welded. Reduced end of diamond shaped knurled stainless-steel rod was placed in the bored hole (diameter 25 mm) of smaller piece of stainless-steel rod and welded.

Methodology

Suitable trees of *Moringa oleifera* were selected at Kankebar, Ramgarh (Jharkhand) to conduct *moringa* gum tapping experiment from *Moringa oleifera* trees and initiated in the last week of July, 2020 with three replicates utilizing developed gum tapping blazer. To develop blaze on the tree trunk of *Moringa oleifera* trees using developed gum tapping blazer, the required depth of working blade was fixed utilizing depth control mechanism provided in the developed blazer based on bark thickness of *Moringa oleifera* trees. After fixing the desired depth of working blade with adjustment of depth control mechanism, the gum tapping blazer was placed on the tree trunk of *Moringa oleifera* 1.0 m above the ground level and hammered thoroughly up to the bark thickness and depth of blaze/incision was maintained utilizing depth control mechanism provided in blazer.

Performance evaluation of the developed gum tapping blazer

To evaluate the performance of the developed gum tapping blazer for *moringa* gum tapping from *Moringa oleifera* trees, selected trees were blazed utilizing developed gum tapping blazer and time requirement for blaze development, size and depth of the developed blaze were measured for each blaze developed on the tree trunk of separate trees.

RESULTS AND DISCUSSION

Natural gums are collected in small quantities by forest dwellers by adopting traditional tapping methods. Tools and technique for different commercially important gums (gum *karaya*, gum *arabic* and *guggul* etc.) tapping has been standardized by previous researchers but improved gum tapping blazer for *moringa* gum tapping from *Moringa oleifera* trees are lacking. Considering the need, a gum tapping blazer was developed at ICAR – National Institute of Secondary Agriculture, Ranchi designed in collaboration with ICAR – Central Institute of Agricultural Engineering, Bhopal utilizing the facility of Pro Engineer (Creo Element) CAD Software so that maximum *moringa* gum may be produced from *Moringa oleifera* trees with minimum injury of uniform size and required depth alongwith reduced time requirement in blaze development. The detailed description of the performance evaluation of the developed gum tapping blazer for *moringa* gum tapping from *Moringa oleifera* trees is as under.

Performance evaluation of the developed gum tapping blazer

During the process of *moringa* gum tapping experiment from

Moringa oleifera trees utilizing developed blazer conducted at Kankebar, Ramgarh (Jharkhand), it was observed that blazes on the tree trunk of *Moringa oleifera* trees were developed easily utilizing developed blazer with sharp edges in semicircular shape having length 75 mm, height 41.5 mm and depth 20.0 mm (Fig. 6 and 7) which starts gum oozing within 4 – 5 hours (Fig. 8). Overall dimension *i.e.* length, width and height of the developed gum tapping blazer was 304×126.5×79 mm, respectively. Developed gum tapping blazer is a small hand tool, light in weight (1.5 kg) and is user friendly. It was also observed that curved face of the working blade and depth control mechanism matches with the circumference of the tree trunk as per requirement for *moringa* gum tapping from *Moringa oleifera* trees. The developed gum tapping blazer was operated easily without any problem. Depth control mechanism for depth adjustment provided in the developed blazer was also found working as per requirement and suitable for operating the blazer easily. Operator did not report any discomfort during operation of the developed gum tapping blazer. A person can develop semicircular shaped blazes on the tree trunk of *Moringa oleifera* tree easily at a suitable height utilizing developed blazer within a minute for *moringa* gum tapping. Hence, blazes with enhanced productivity of gum tappers can be developed on the tree trunk of *Moringa oleifera* trees for *moringa* gum tapping with reduced manpower requirement, drudgery and time.



Fig. 6: Blaze development using gum tapping blazer



Fig. 7: Developed blaze



Fig. 8: Gum exudation from developed blazer

Moringa gum yield from *Moringa oleifera* trees

Mean yield of *moringa* gum was found 59.76 g with minimum mean gum production as 2.19 g in the month of October, 2020 and maximum 257.85 g mean gum production in the month of July, 2021, respectively. Mean total *moringa* gum production during the experiment duration (August, 2020 – July, 2021) was collected to be 717.15 g, respectively from three trees in actual field condition utilizing developed gum tapping blazer. Maximum monthly *moringa* gum was collected in the month of July, 2021 (257.85 g) followed by May, 2021 (224.85 g), June, 2021 (138.99 g), August, 2020 (38.06 g), January, 2021 (16.97 g), December, 2020 (9.09 g), November, 2020 (8.11 g), April, 2021 (6.35 g), March, 2021 (6.10 g), September, 2020 (4.73 g), February, 2021 (3.86 g) and October, 2020 (2.19 g), respectively. A regular increasing trend in *moringa* gum yield observed with increase in environmental temperature which indicates that *moringa* gum can be tapped throughout the year but higher quantity of gum may be collected during April – September.

CONCLUSION

Developed gum tapping blazer is a small hand tool, light in

REFERENCES

- Das, Bhushan I. 2014. Identification of Physiological Tools for Gum Extraction. *M.Sc. (Ag.) Thesis*, Department of Plant Physiology, Agricultural Biochemistry, Medicinal and Aromatic Plants Indira Gandhi Krishi Vishwavidyalaya, Raipur (C.G.), 83 pp.
- Giri SK, Prasad N, Pandey SK, Prasad M and Baboo B. 2008. Natural Resins and Gums of Commercial Importance – At a Glance. *Technical Bulletin*, Indian Institute of Natural Resins & Gums, Ranchi, 1-38.
- Gordon ER, Rosanka TW, Fonner OE, Anderson NR, and Banker GS. 1990. *Pharmaceutical Dosage Forms*, Liberman HA, Lachman L, Schwartz, editors. (Marcel Dekker, New York, 2nd edition), pp. 83.
- Lakshmi Priya G, Kruthi D and Devarai SK. 2016. *Moringa oleifera*: A review on nutritive importance and its medicinal application. *Food Science and Human Wellness* 5:49–56.
- Prasad N, Sharma KR, Tiwari JC, Gupta R and Thomas M. 2012. Mechanization of natural gum and resin tapping. *Journal of*

weight and is user friendly. Curved face of the working blade and depth control mechanism matches with the circumference of the tree trunk as per requirement for *moringa* gum tapping from *Moringa oleifera* trees. Developed gum tapping blazer was operated easily without any problem, depth control mechanism provided was found working as per requirement and suitable for operating the blazer easily. Semi circular blazes on the tree trunk of *Moringa oleifera* trees for *moringa* gum tapping with enhanced productivity of gum tappers can be developed easily with reduced manpower requirement, drudgery and time utilizing developed gum tapping blazer. Blazes on the tree trunk of *Moringa oleifera* trees were developed easily utilizing developed blazer with sharp edges in semi-circular shape of desired size which starts gum oozing within 4–5 hours.

ACKNOWLEDGEMENT

The authors express their sincere thanks to Dr. K K Sharma, Director, ICAR – National Institute of Secondary Agriculture (Formerly: Indian Institute of Natural Resins and Gums), Ranchi for constructive suggestions throughout the present investigation. Authors are thankful to Dr. K K Singh, Former Director, ICAR – Central Institute of Agricultural Engineering, Bhopal and their scientific staff for constructive support and technical staff for development of detailed manufacturing design drawing of the developed gum tapping blazer. Authors also acknowledge the support provided during experimentation by Er. Anmol Kumar Mishra, Senior Research Fellow, ICAR – National Institute of Secondary Agriculture, Ranchi. Financial support provided by Indian Council of Agricultural Research, New Delhi for the investigation as sub-project under All India Network Project on Harvesting, Processing and Value Addition of Natural Resins and Gums is thankfully acknowledged.

CONFLICT OF INTEREST

All the author both individually and collectively, affirms that they do not possess any conflicts of interest either directly or indirectly related to the research being reported in the publication.

Non – Timber Forest Products 19(4): 279–289.

- Shah DP, Jain VC, Dalvadi HP, Ramani VD, Patel KG, Saralal MG and Jani GK. 2011. A Preliminary Investigation of *Moringa Oleifera* Lam Gum As a Pharmaceutical Excipient. *International Journal of Pharmacy Research and Technology* 1(1):12-16.
- Sharma SC and Prasad N. 2013. Comparison of Gum Tapping Techniques for Gum *Karaya*: A Gum of Commercial Importance. *Journal of Non-Timber Forest Products* 20(3): 165–170.
- Sharma SC, Pandey SK and Prasad N. 2023. Mechanization Status in *Karaya* Gum Tapping and Scope for Improvement: A Review. *Agricultural Mechanization in Asia, Africa and Latin America* 54(2):18–29.
- Sharma SC, Prasad N, Pandey SK and Giri SK. 2016a. A Review on Status of Gum Tapping and Scope for Improvement. *Agricultural Mechanization in Asia, Africa and Latin America* 47(3):68–75.
- Sharma SC, Prasad N, Pandey SK and Giri SK. 2018b. Status of

- Resin Tapping and Scope of Improvement: A Review, *Agricultural Mechanization in Asia, Africa and Latin America* **49** (3): 16–26.
- Sharma SC, Prasad N, Pandey SK and Kar Amit K. 2018c. Studies on Engineering Properties of Selected Natural Exudate Gums. *Journal of Agricultural Engineering* **55** (1): 54–63.
- Sharma SC, Prasad N, Pandey SK and Singh R. 2018a. Mechanization Status in Commercially Important NRGs Production - A Review. *Multilogic In Science* **VIII**, Issue Special (E): 353–357.
- Sharma SC, Prasad N, Sharma KR and Chanderekha. 2013. Development and Evaluation of Freshening Tools for Enhancing Resin Yield from *Chir* Pine (*Pinus roxburghii*) using Bore Hole Method of Resin tapping. *Agricultural Engineering Today* **37** (2): 42–50.
- Sharma SC, Tewari JC, Prasad N, Pandey SK and Kar Amit K. 2016b. Manual on Gum Inducer Technique for Gum Tapping from *Acacia senegal*, ICAR–Indian Institute of Natural Resins and Gums, Ranchi (Jharkhand), India. Bulletin (Technical) No.: **15/2016**, 1-27pp.
- Shivalingam MR, Arul Kumaran KSG, Reddy YVK, Jeslin D, Tejaswini M, Rao CM and Chaitanya BS. 2010. Evaluation of binding properties of *Moringa oleifera* gum in the formulation of paracetamol tablets. *Drug Invention Today* **2**: 69-71.
- Thombare N, Lohot VD, Prasad N and Sharma KK. 2018. Major gum and resin plants of India: A field guide. ICAR – Indian Institute of Natural Resins and Gums, Ranchi. pp i-vi, 1-128.

Citation:

Sharma SC, Pandey SK, Prasad N and Raj H. 2024. Revolutionizing Gum Tapping: A Manual Blazer for *Moringa oleifera* Gum Tapping. *Journal of AgriSearch* **11**(1): 58-63